

AireTile™  
Fan Assisted Floor Tile



Technical Manual



ISO 14001  
EMS52086



ISO 9001  
FM00542

## Customer Services

### Warranty, Commissioning & Maintenance

As standard, Airedale guarantees all non consumable parts only for a period of 12 months, variations tailored to suit product and application are also available; please contact Airedale for full terms and details.

To further protect your investment in Airedale products, Airedale can provide full commissioning services, comprehensive maintenance packages and service cover 24 hours a day, 365 days a year (UK mainland). For a free quotation contact Airedale or your local Sales Engineer.

All Airedale products are designed in accordance with EU Directives regarding prevention of build up of water, associated with the risk of contaminants such as Legionella.

For effective prevention of such risk it is necessary that the equipment is maintained in accordance with Airedale recommendations.

### SafeCool

In addition to commissioning, a 24 hour, 7 days a week on-call service is available throughout the year to UK mainland sites. This service will enable customers to contact a duty engineer outside normal working hours and receive assistance over the telephone. The duty engineer can, if necessary, attend site, usually within 24 hours or less. Full details will be forwarded on acceptance of the maintenance agreement.

### CAUTION

Warranty cover is not a substitute for maintenance. Warranty cover is conditional to maintenance being carried out in accordance with the recommendations provided during the warranty period. Failure to have the maintenance procedures carried out will invalidate the warranty and any liabilities by Airedale International Air Conditioning Ltd.

### Spares

A spares list for 1, 3 and 5 years will be supplied with every unit and is also available from our Spares department on request.

### Training

As well as our comprehensive range of products, Airedale offers a modular range of Refrigeration and Air Conditioning Training courses, for further information please contact Airedale.

### Customer Services

For further assistance, please e-mail: [enquiries@airedale.com](mailto:enquiries@airedale.com) or telephone:

UK Sales Enquiries	+ 44 (0) 113 239 1000	<a href="mailto:enquiries@airedale.com">enquiries@airedale.com</a>
International Enquiries	+ 44 (0) 113 239 1000	<a href="mailto:enquiries@airedale.com">enquiries@airedale.com</a>
Spares Hot Line	+ 44 (0) 113 238 7878	<a href="mailto:spares@airedale.com">spares@airedale.com</a>
Airedale Service	+ 44 (0) 113 239 1000	<a href="mailto:service@airedale.com">service@airedale.com</a>
Technical Support	+ 44 (0) 113 239 1000	<a href="mailto:tech.support@airedale.com">tech.support@airedale.com</a>
Training Enquiries	+ 44 (0) 113 239 1000	<a href="mailto:marketing@airedale.com">marketing@airedale.com</a>

For information, visit us at our web site: [www.airedale.com](http://www.airedale.com)

Airedale Ltd endeavours to ensure that the information in this document is correct and fairly stated, but none of the statements are to be relied upon as a statement or representation of fact. Airedale Ltd does not accept liability for any error or omission, or for any reliance placed on the information contained in this document. The development of Airedale products and services is continuous and the information in this document may not be up to date. It is important to check the current position with Airedale Ltd at the address stated. This document is not part of a contract or licence unless expressly agreed. No part of this document may be reproduced or transmitted in any form or by any means, electronic or mechanical, including photocopying, recording, or information storage and retrieval systems, for any purpose other than the purchaser's personal use, without the express written permission of Airedale Ltd.

© 2014 Airedale International Air Conditioning Limited. All rights reserved. Printed in the UK.

**Health and Safety****IMPORTANT**

The information contained in this manual is critical to the correct operation and maintenance of the unit and should be read by all persons responsible for the installation, commissioning and maintenance of this Airedale unit.

**Safety**

The equipment has been designed and manufactured to meet international safety standards but, like any mechanical/ electrical equipment, care must be taken if you are to obtain the best results.

**CAUTION**

When working with any air conditioning units ensure that the electrical isolator is switched off prior to servicing or repair work and that there is no power to any part of the equipment.

Also ensure that there are no other power feeds to the unit such as fire alarm circuits, BMS circuits etc.

Electrical installation commissioning and maintenance work on this equipment should be undertaken by competent and trained personnel in accordance with local relevant standards and codes of practice.

**Personal Protective Equipment**

Airedale recommends that personal protective equipment is used whilst installing, maintaining and commissioning equipment.

**Manual Handling**

Some operations when servicing or maintaining the unit may require additional assistance with regard to manual handling. This requirement is down to the discretion of the engineer.

Remember do not perform a lift that exceeds your ability.

**Environmental Policy**

It is our policy to:

- Take a proactive approach to resolve environmental issues and ensure compliance with regulatory requirements.
- Train personnel in sound environmental practices.
- Pursue opportunities to conserve resources, prevent pollution and eliminate waste.
- Manufacture products in a responsible manner with minimum impact on the environment.
- Reduce our use of chemicals and minimise their release to the environment.
- Measure, control and verify environmental performance through internal and external audits.
- Continually improve our environmental performance.

**CE Directive**

Airedale certify that the equipment detailed in this manual conforms with the following EC Directives:

Electromagnetic Compatibility Directive (EMC)	2004/108/EC
Low Voltage Directive (LVD)	2006/95/EC
Machinery Directive (MD)	89/392/EEC version 2006/42/EC
Pressure Equipment Directive (PED)	97/23/EC

To comply with these directives appropriate national & harmonised standards have been applied. These are listed on the Declaration of Conformity, supplied with each product.

## Contents

<b>Customer Services</b>	<b>2</b>
Health and Safety	3
Manual Handling	3
Environmental Policy	3
<b>Specifiers Guide</b>	<b>5</b>
Nomenclature	5
Introduction	5
Airflow Configuration	7
<b>Controls</b>	<b>8</b>
Controls Overview	8
IR33 Parametric Controller	9
PLD Programmable LCD Display	10
PC05 Programmable Logic Controller	11
Control Configurations	12
<b>Technical Data</b>	<b>15</b>
Mechanical Data	15
Electrical Data	15
Noise Data	15
<b>Installation Data</b>	<b>16</b>
Dimensions	16
Control Wiring Termination	17
Customer Interconnecting Wiring	18
Display Location	19
Display Connections	20
Pedestal	21
Minimum Clearance	22
<b>Controls</b>	<b>23</b>
Addressing the display	23
pLD Display Keypad	24
IR33 Controller	25
<b>Alarms</b>	<b>26</b>
T0 & TS, Alarms	26
TM Alarms	26
TX Alarms	26
V0 Alarms	27
<b>Troubleshooting</b>	<b>28</b>
<b>After Sales</b>	<b>29</b>
Warranty	29

**Specifiers Guide**

**Nomenclature**

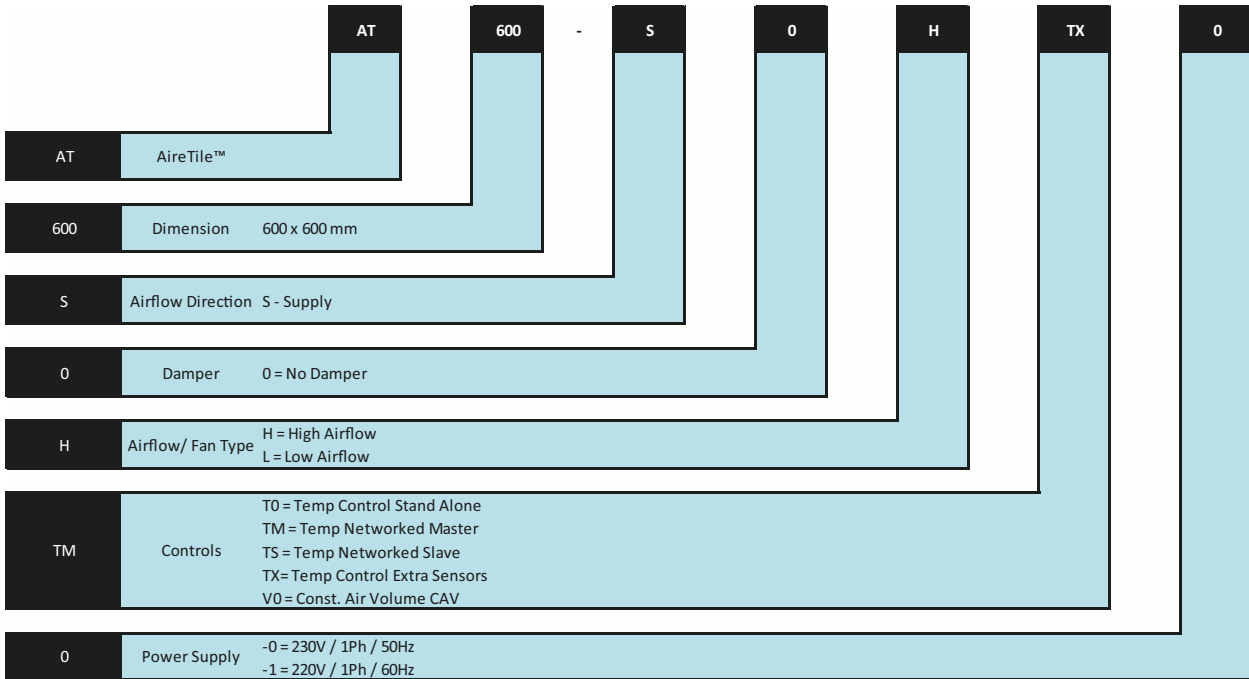

**Introduction**

Data centres are a rapidly growing industry in which companies are constantly competing to utilise space more efficiently and reduce operating costs. Since the advent of Blade Server technology a 42U server rack is able to be loaded such that its cooling requirement could be up to 30kW. In order to effectively cool a server with a 30kW heat load, the server must be supplied with 1 m<sup>3</sup>/s of conditioned air.

The AireTile unit has been designed to provide additional conditioned air to high density server racks and as a solution to problems caused by high density servers in aisle containment.

**Construction**

The AireTile shall be manufactured with galvanised sheet steel to provide a smooth aesthetically pleasing finish.

Standard unit colour shall be Black Grey to RAL 7021.

Unit Overview

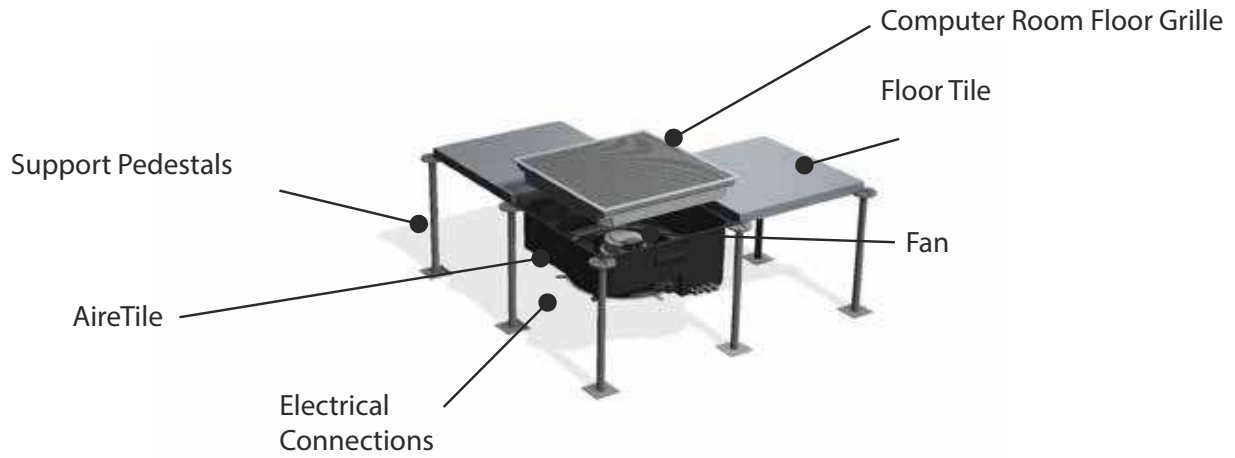

	T0	TM & TS	TX	V0
High Airflow Fan	●	●	●	●
Low Airflow Fan	●	●	●	●
Heavy Duty Floor Grille	●	●	●	●
Extra Heavy Duty Floor Grille	●	●	●	●
Parametric Controller	●	●	—	—
Programmable Logic Controller	—	●	●	●
Infra-Red Remote Control	○	○	—	—
Fan Control 0-10V	●	●	●	●
Standalone Operation	●	—	●	●
Networked Operation	—	●	●	●
Temperature Control (two sensors)	●	●	●	●
Temperature Control (up to 6 sensors)	—	—	●	●
Temp & Differential Pressure Control	—	—	—	●
Constant Air Volume CAV Control	—	—	—	●
Display Fan Control Voltage	●	●	●	●
BMS Interface (Modbus only)	○	●	●	●
BMS Interface (other manufacturer)	—	—	○	○

● Standard Feature ○ Optional Feature — Not Available



The grille is able to be integrated with a range of raised access floors via a configurable cut-out in each corner where the depth can be adjusted to the required floor tile depth. Designed to integrate with raised access floor and to be installed into a 600 x 600 floor tile/ grille

The grilles are available for use with a range of floor tile depths dependant on customers' requirements. Standard tile depth 35 to 50mm. Please contact Airedale for other options. Tile depth to be specified at time of order.

The AireTile unit will be integrated with an air distribution grille to effectively supply conditioned air to a server room.  
 The British Standard BS 6399: Part 1 details the minimum requirement for 'rooms with mainframe computers' as 4.5 kN concentrated load.  
 The standard Floor Mounted Air Terminal Devices – Test for Structural Classification BS EN 13264:2001 has been written specifically for floor grilles and states that grilles should be load rated to heavy duty or extra heavy duty and meet the minimum requirement for a computer equipment room, summarised in the table below.

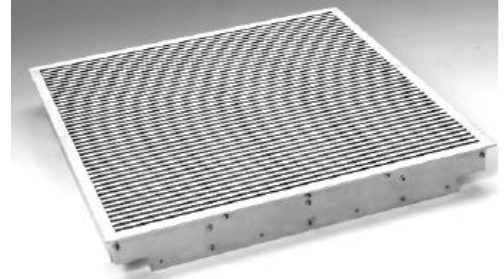

Structural Class (Computer Room Floor Grille)	Load
Heavy	4.5 kN over 25 mm x 25 mm area
Extra Heavy	4.5 kN over 25 mm 25 mm area, whilst also supporting 11 kN over 4 off 25 mm x 25 mm areas

**Airflow Configuration**

The AireTile unit has the option to select two fans depending on the material cost and server heat load / conditioned air requirement.

**High Airflow**

The high airflow fan has been sized to meet and exceed the current cooling requirement of even the most densely populated racks.  
 The high airflow fan can deliver over 1 m³/s which will provide cooling for servers with up to 30 kW heat load.

**Low Airflow**

The low airflow fan has been selected to meet the cooling demands of server racks which are medium to highly populated, but have an airflow requirement of less than 0.74 m³/s

**IEC 60309 Plug and Socket**

A IEC 60309 plug and socket shall be fitted enabling quick connection of power to the unit.

## Controls

### Controls Overview

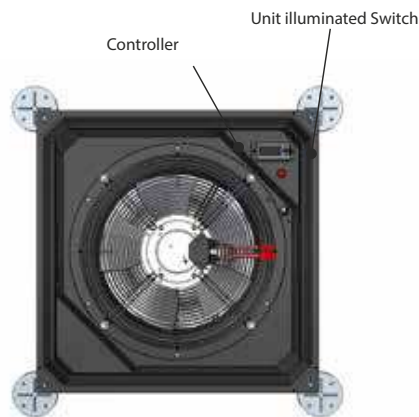

The AireTile units will come with 5 different controls options. All of these options share the same basic operation, but differ slightly in features and functionality. These unit types are differentiated by the 5 different controls options shown in the nomenclature T0, TM & TS, TX, V0.

The basic operation of all the configurations actively modulates the fan speed using PID control in order to maintain a set temperature condition (set point). Except the V0 or CAV unit which controls to maintain a set differential pressure. However if temperature rises above pre-set max limit, it will then control to temperature and once the temperature is below limit it will resume CAV control.

This will work using 'direct' control, where the fan is switched on and regulated in order to reduce the temperature at the inlet of the server rack once it exceeds the desired set point. The speed of the fan is determined by how far above the set point the temperature is.

The integral and derivative terms used to increase the accuracy of the PID control are also programmable.

Temperature is measured using a minimum of two NTC probes, controlling to the highest temperature. (T0, TM and TS) or averaged with the TX and V0 units.

The value of the set point is configurable by the user between 10°C and 50°C, and the factory default is 24°C.

The fan on each unit will be regulated using a 0-10V control signal sent as an analogue output from the controller. Standard minimum and maximum values are set to 1.5V and 10V respectively; however, this may change depending on the maximum acceptable airflow of the application in which the unit is commissioned, and is also configurable by the user.



Controls

IR33 Parametric Controller

T0 TS Units

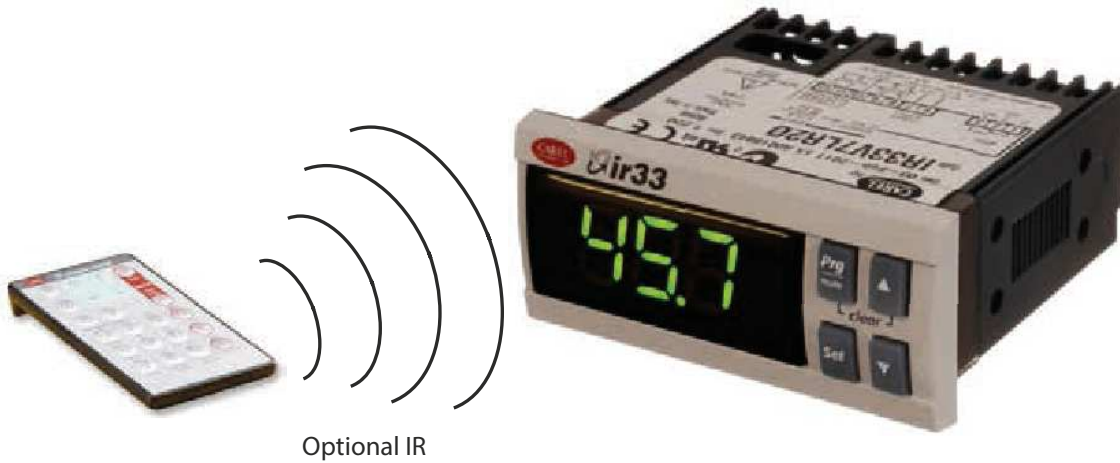

The Carel IR33 is a basic, compact and cost effective parametric controller. Preloaded with a standard software strategy, it allows limited programming through defining various options and parameters that give it the ability to perform a range of common operating modes. The semi-programmable nature of the IR33 makes it an ideal quick solution for simple applications where basic PID control is required.

A separate infrared keypad allows remote control of the IR33, giving the ability to easily modify unit parameters. One keypad can be used to communicate with any units within range individually by using an addressing system. With the addition of an RS485 serial card add in module, the IR33 can also communicate with other controllers over the Modbus interface.

The T0 and TS controls options both use an IR33 each as their main controller to provide basic temperature based fan modulation. The TS also makes use of the RS485 serial card, adding networking functionality.

The IR33 has a built in 7 segment display used to display and change set points, options and temperature readings.

Infrared Remote Control.



The IR33 controller has the facility to be used in conjunction with an infrared remote control. This remote is provided with the T0 and TS AireTile units as an optional extra. This allows remote control of the units including modifying set points, clearing and viewing alarms and switching units on and off. One remote control can interface with many units one at a time; this is achieved by inputting

the address of the required unit after pressing the  button.

Controls

Intobin

PLD Programmable LCD Display

All pCO5 Compact based units



The pLD PRO display is a new piece of hardware that retains all the functionality of the pGD1 display in a more compact package.

The pLD PRO displays masks in the same way as the pGD1 but with a much higher pixel density, allowing the display to fit in the same physical footprint as the IR33 display.

All units with a pCO5 Compact controller will have a pLD PRO display. These are the units with the TM, TX and V0 controls options.

## Controls

### PC05 Programmable Logic Controller

### TM, TX and V0 units



The pCO5 Compact is a smaller version of the pCO5 controller designed for use in space sensitive applications. Like the pCO5, the Compact is fully programmable.

Fully programmable controller.

- 10 inputs (8 analogue, 2 digital)
- 9 outputs (2 analogue, 7 digital)
- Programmable modbus interface

The TM, TX and V0 controls options all use the pCO5 Compact with various different features enabled from unit to unit in order to give a wider range of possible applications.

The features are managed in the controls strategy, with all pCO5 Compact units sharing the same software.

Control Configurations

Configuration 1. Temperature Only Standalone Units  
T0

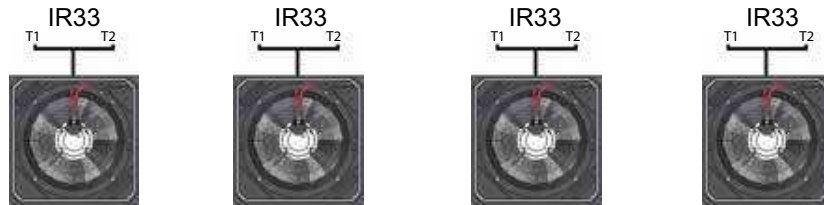

Configuration 2. Temperature Only Networked units

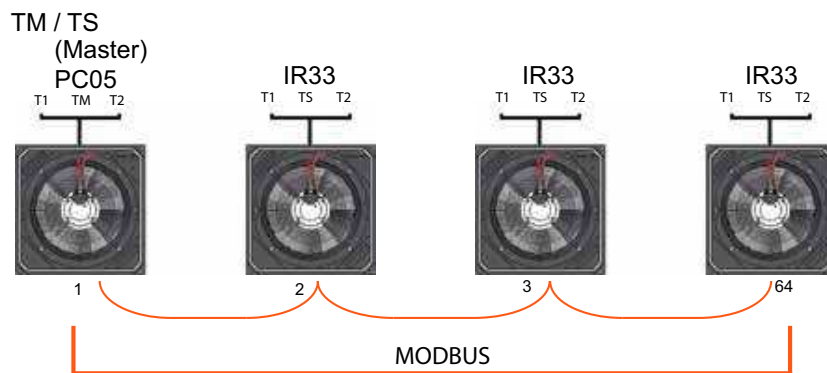

Configuration 3. Temperature Only (extra sensors) Networked or Standalone

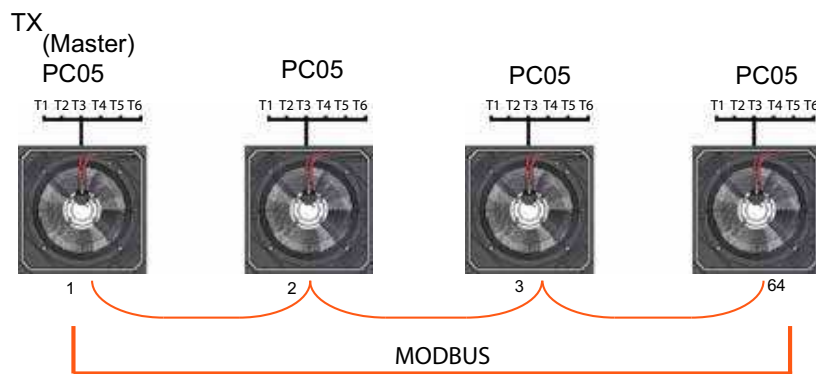

Configuration 4. Pressure + temperature Networked or Standalone  
V0

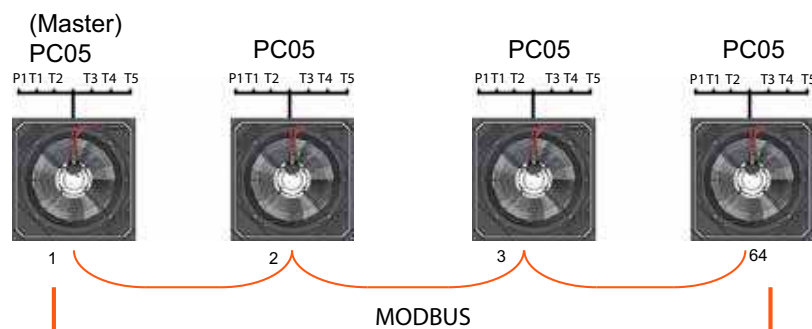

**Temperature Sensor**

Secondary temperature sensors shall be used in case of primary sensor failure. It's also used to provide a better coverage of temperatures on the server rack when calculating maximum and/ or average temperatures.

**Constant Air Volume (CAV) (V0 units)**

Constant air volume shall be fitted to the V0 units. This ensures that the correct amount of air is delivered by the AireTile unit based on customer requirements.

**Modbus/ Carel BMS Connection**

The Airedale controllers are able to communicate directly using the Modbus® protocol.

The Modbus® card is a small PCB (60mm x 30mm), which can be plugged into the controller to provide it with the following protocol support

- Modbus® - JBus slave
- RTU mode (Remote Terminal Unit) with 8 bit encoding and error handling using 16 bit CRC
- Communication standard connection options of RS485 (multipoint) or RS232 (point-point)
- Maximum Baud Rate of 19200

The data communication is asynchronous serial, 8 data bits, 2 stop bits and no parity (in total 11 bits/datum).

The data / parameters from the controller is represented within Modbus® registers, each register containing information pertaining to temperatures, pressures, set points, status, etc and is available to the site integration company in a spreadsheet format

**Measurement of Sound Data**

All sound data quoted has been measured in the third-octave band limited values, using a Real Time Analyser calibrated sound intensity meter in accordance with BS EN ISO9614 Part 1: 1995.

All Sound Power Levels quoted are calculated from measured sound intensity according to BS EN ISO9614 Part 1: 1995

Semi Hemispherical

Sound Pressure Levels are calculated from sound power using the semi-hemispherical method where the noise source is in junction with 2 boundaries i.e. the floor and 1 wall.

Free Field

For comparison, the semi hemispherical figures can typically be reduced by 3dB to provide free field conditions.

Technical Data

Mechanical Data

Mechanical Data		230V 50Hz -0		220V 60Hz -1	
		High	Low	High	Low
Construction		Sheet steel, epoxy baked powder paint			
Colour		Black Grey (RAL 7021)			
<b>Fan - Per Fan</b>					
Motor Type		EC	EC	EC	EC
Quantity x Motor Size	W	1 x 400	1 x 140	1 x 400	1 x 140
Max Fan Speed	rpm	1720	1055	1720	1055
Nominal Airflow	m³/s	1.0	0.7	1.0	0.7
Fan Power (@ nominal airflow)	W	250	120	250	120
Dimensions (T0,TS, TM,TX)	mm	595 x 595 x 250		595 x 595 x 250	
Dimensions (V0)	mm	596 x 595 x 380		596 x 595 x 380	
Case Weight (T0,TS / TM,TX,V0)	kg	15 / 18		15 / 18	
Fan Weight	kg	9		9	
Unit Weight no grille (T0, TS / TM, TX, V0)	kg	24 / 27		24 / 27	
Floor Grille Weight	kg	11		11	
Total Unit Weight with grille (T0, TS / TM, TX, V0)	kg	35 / 38		35 / 38	

Additional space is required under the floor for the control panel.

Electrical Data

Electrical Data		230V 50Hz -0		220V 60Hz -1	
		High Air Flow	Low Air Flow	High Air Flow	Low Air Flow
Nominal Run Amps	A	3.1	1.65	3.1	1.65
Maximum Start Amps	A	3.1	1.65	3.1	1.65
Recommended Mains Fuse Size	A	10	10	10	10
Mains Supply	VAC	230	230	220	220
Control Circuit	VAC	24	24	24	24
<b>Fan - Per Fan</b>					
Motor Type		EC	EC	EC	EC
Quantity x Motor Size	W	1 x 400	1 x 140	1 x 400	1 x 140
Full Load Amps	A	2.6	1.15	2.6	1.15

Noise Data

		NR	63 Hz	125 Hz	250 Hz	500 Hz	1000 Hz	2000 Hz	4000 Hz	8000 Hz	dB(A) Overall A-Weighted
1.0m³/s	Sound Power dB(A)	63	66	78	71	72	77	73	70	60	82
	Sound Pressure dB(A) at 3 m		52	63	57	58	63	58	55	46	68
0.7m³/s	Sound Power dB(A)	48	71	71	66	63	62	58	51	45	75
	Sound Pressure dB(A) at 3 m		57	57	51	48	48	43	36	31	61

**Installation Data**

**Dimensions**

**T0 / TS**

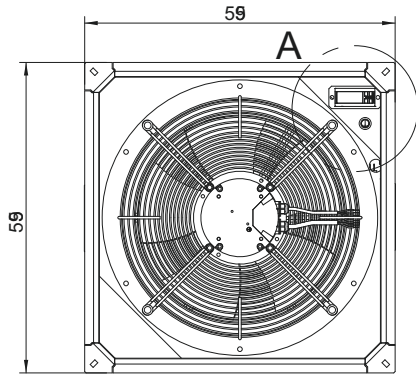

**TM, TX, V0**

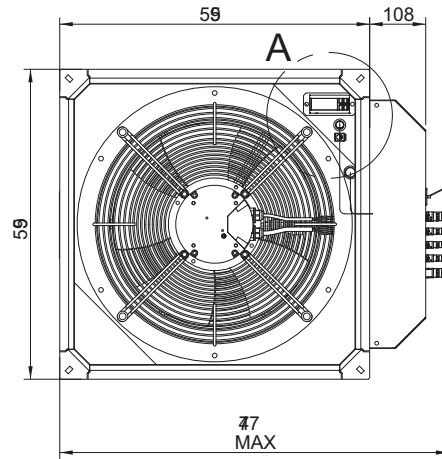

**T0 / TS / TM, TX,**

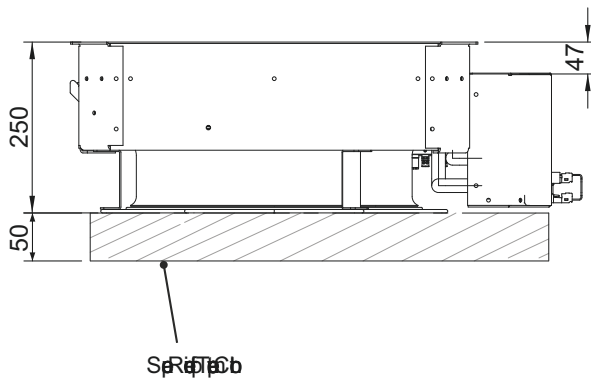

**V0**

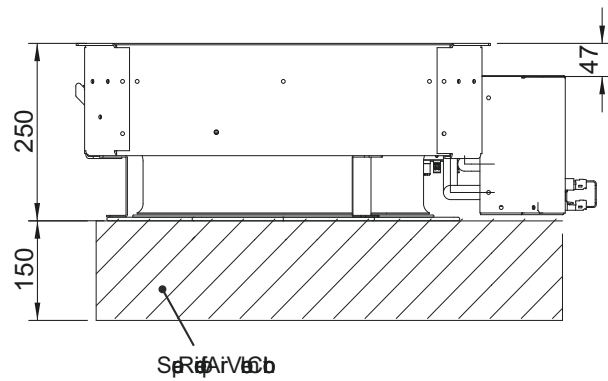

**Floor Void Depths**

- T0 / TS / TM TX = 300mm
- V0 = 400mm



Installation Data

Control Wiring Termination



T0 / TS

TM, TX, V0

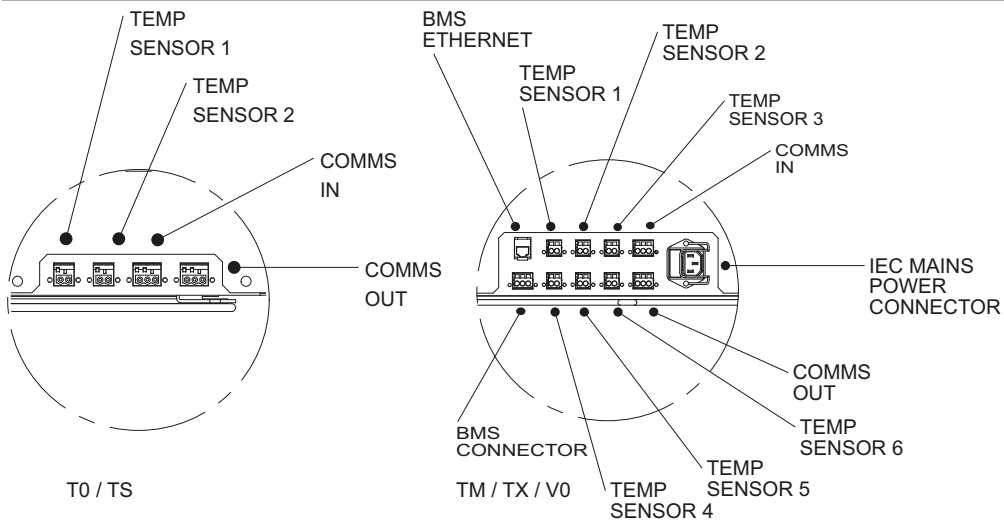
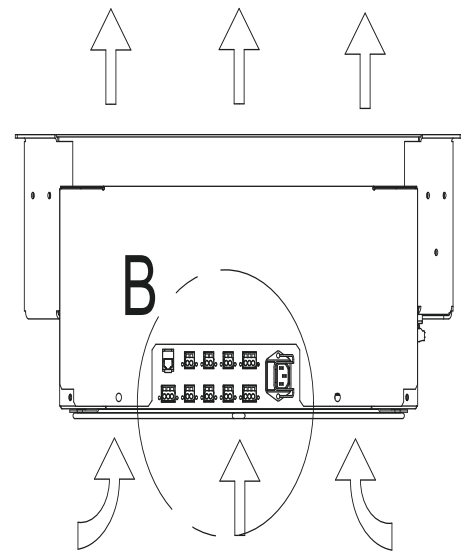
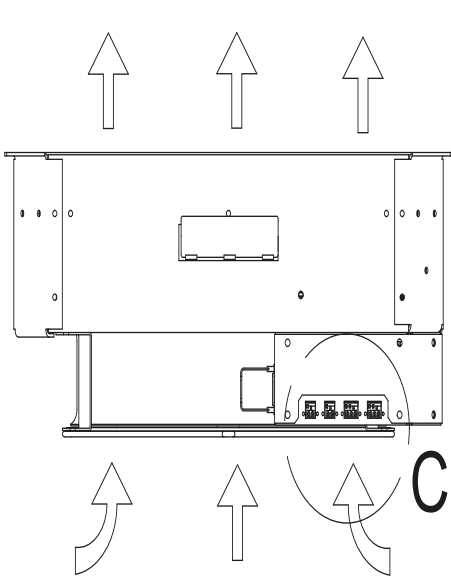
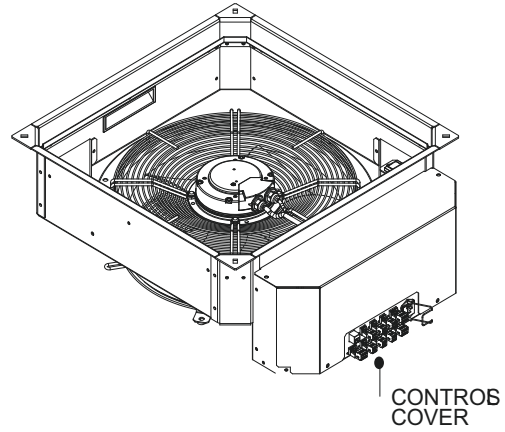
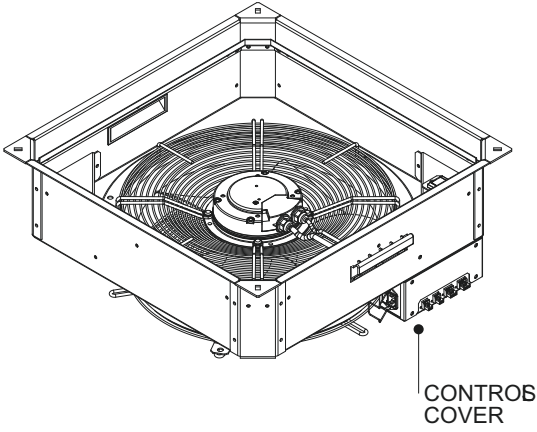

## Installation

### Customer Interconnecting Wiring

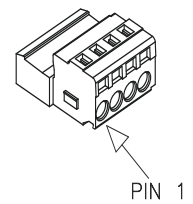
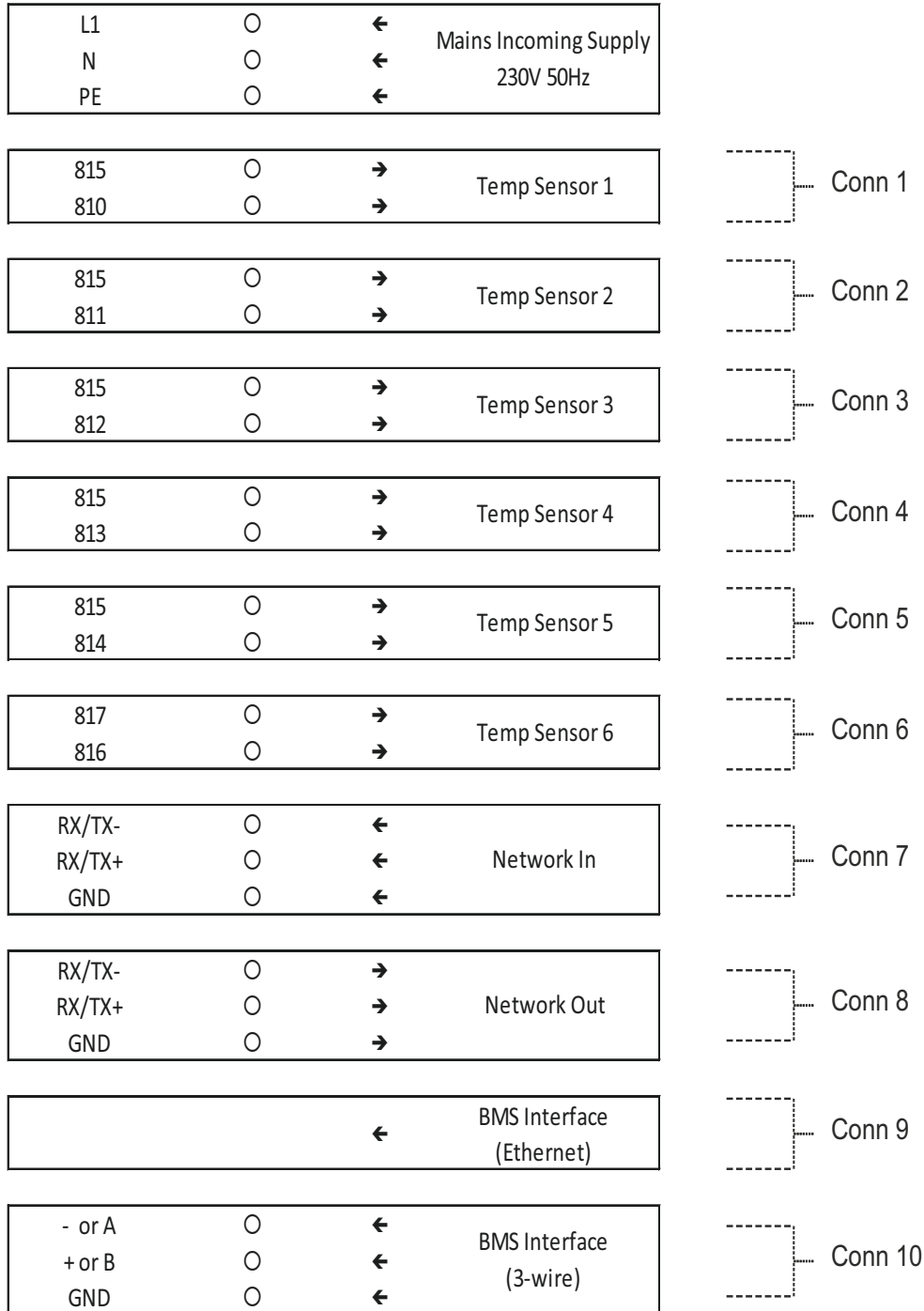

Installation Data

Display Location



T0

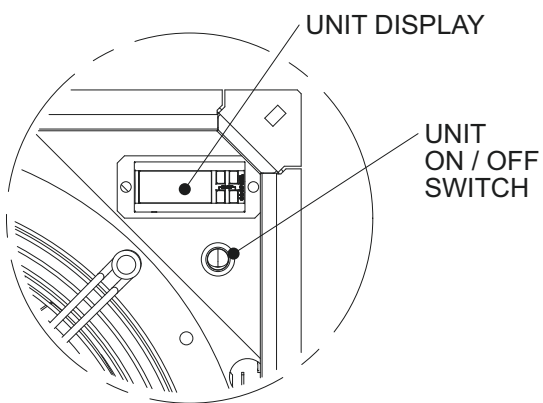

TM, TX and V0

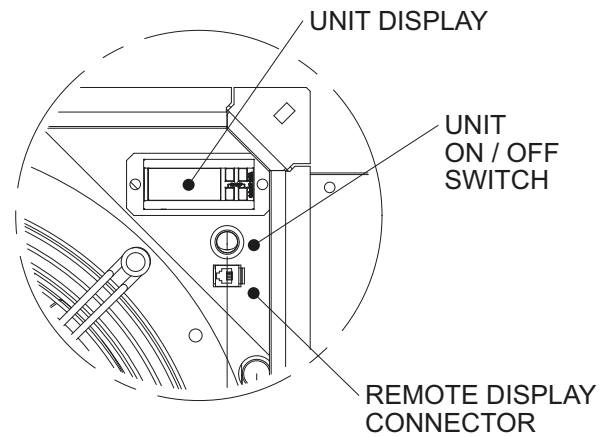

## Controls

### Display Connections

The pLD PRO connects to the pCO5 Compact via an RJ11 cable, the connector for which is located on the back of the display.

19

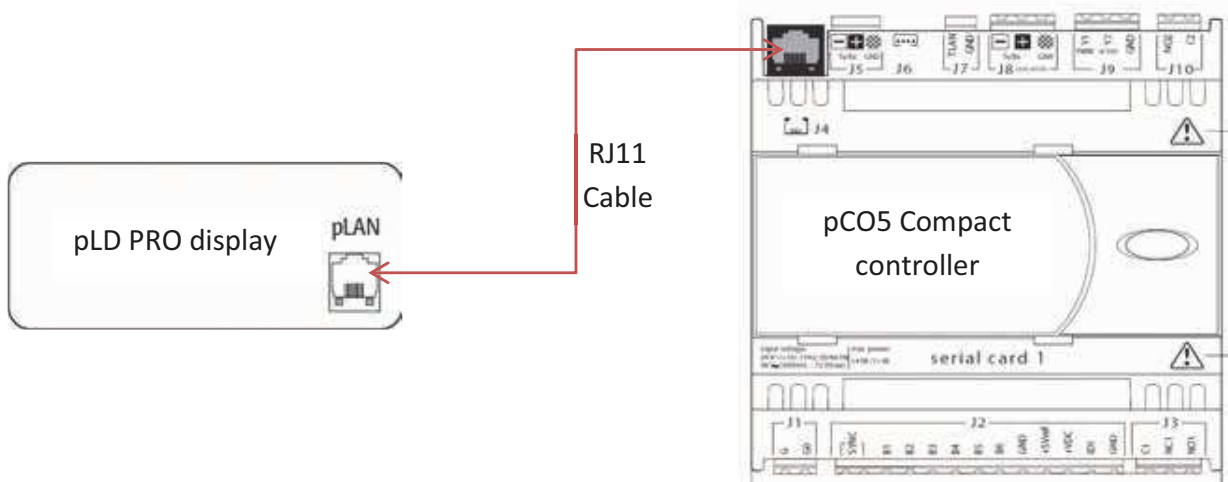

Installation Data

Pedestal

Install AireTile Fan on Floor Pedestal

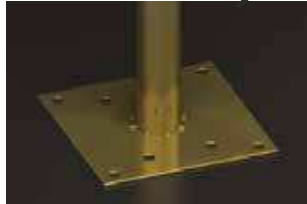

Position Grille above AireTile

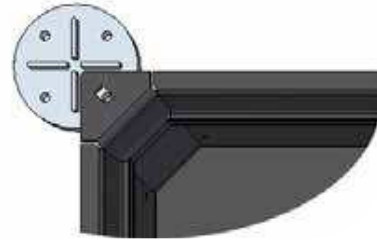

Position floor Tiles





 Take Care when lifting tiles that hands or cables are not trapped.

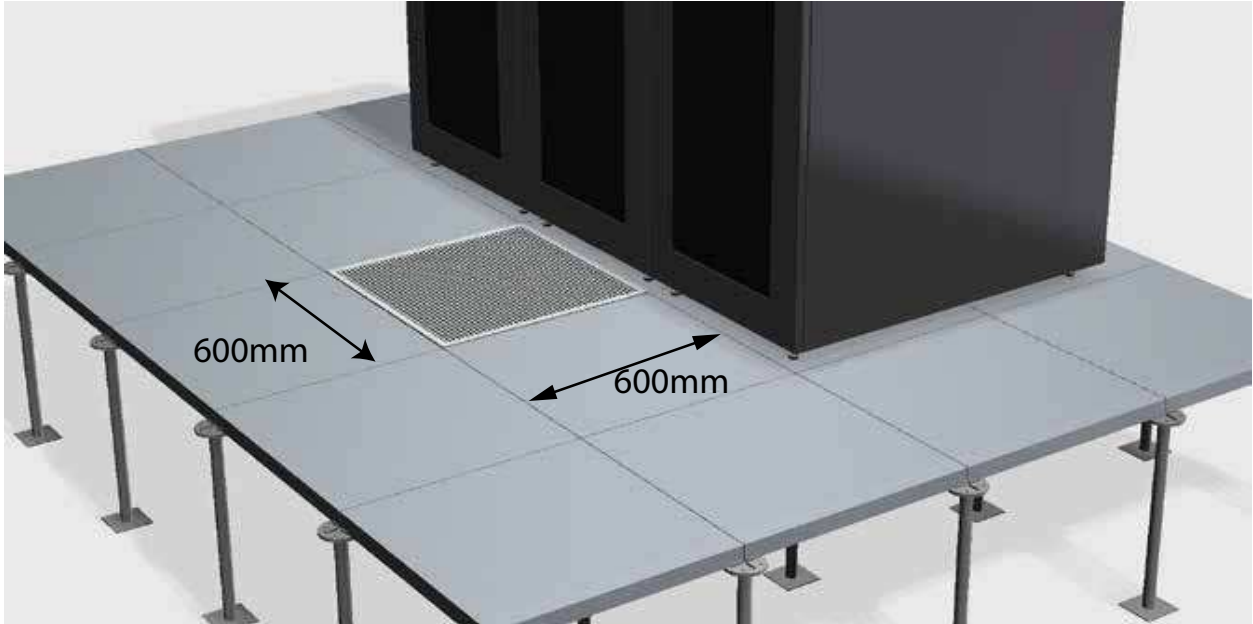

Installation Data

Minimum Clearance



 Clearance is required for the AireTile grille to be removed. Multiple floor tiles may need to be raised during installation and commissioning.



### Controls

#### Addressing the display

To access the configuration mode, press the  +  +  buttons simultaneously (or the  +  +  buttons if using a remote pDG1 display) and hold them for at least 5 seconds; the following screen will be displayed.





To change the address of the display keypad (display address setting), press the  button once.

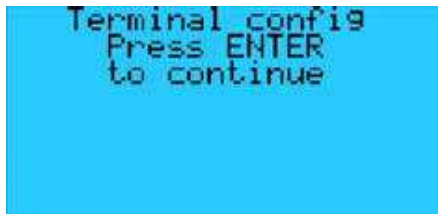

The cursor will move to the display address setting field. Use the  +  buttons to select the desired value, and press  again to confirm. The following screen will be displayed:

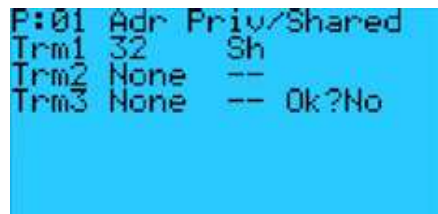



Pressing  again will show the following terminal configuration screen:







Selecting Terminal 1 – Press  until the cursor is underneath Trm1 nn Sh.

Pressing  +  will change the nn to the required value 32.

Selecting private or Shared – Press  until the cursor is underneath the Pr (private) or Sh (shared) symbol.

Pressing  +  will change the Pr to Sh and vice versa. As standard the display should be shared.

Press  until the cursor is underneath the NO.

Pressing  +  will change the NO to YES. Press  and the display is programmed.

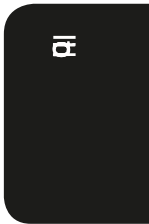

**Controls**

**pLD Display Keypad**



Display	Function	Description
	1. ALARM	When one or more alarms are active the ALARM button will illuminate red. Pressing the ALARM button once will indicate information regarding any active alarms. Pressing the ALARM button twice will reset any active manual-reset alarms.
	2. PRG	Pressing the PRG button will select the main navigation menu.
	3. ESC	Pressing the ESC button will return the user to the main display screen showing unit status.
	4. UP	Pressing the UP button can either: Scroll through the various display screens, providing the cursor is in the top left position. Increase the value of a set point adjustment.
	5. ENTER	Pressing the ENTER button will confirm any set point adjustments and move the cursor to the next available set point.
	6. DOWN	Pressing the DOWN button can either: Scroll through the various display screens, providing the cursor is in the top left position. Decrease the value of a set point adjustment.

Display	Key Combinations	Description
	UP + DOWN+ PRG	Allows access to controller address.
	ALARM + ENTER	Allows access to controller system information.
	ALARM + UP	Allows access to change controller address (only when display address is zero).
	ESC + ENTER	Allows the user to switch between the pre-installed languages.
	PRG + ENTER	Temporarily displays the address of the controller.
	ENTER + UP	Change unit on remote display keypad.



Controls

IR33 Controller



The user interface found built in to the Carel IR33 controller, and subsequently used on the T0 & TS AireTile units is a 3 digit 7 segment display used to show essential information such as temperatures, set points, alarms and pre-set variables. The user can interact with the IR33 using the infrared remote as mentioned previously, or using the four buttons found to the right of the 7 segment display.

Button	Function	Description
	1. PRG / MUTE	Pressing PRG once will mute any alarms. Holding PRG down for 5 seconds accesses the menu for setting user parameters. Holding PRG down for 5 seconds in the settings menu saves all new settings. Holding PRG down for 5 seconds at start up resets the IR33.
	2. SET	Holding the SET button for more than 1 seconds displays and/or sets a parameter value.
	3. UP	Pressing the UP button can either: - Scroll through the various parameters and screens. - Increase the value of a set point adjustment.
	4. DOWN	Pressing the DOWN button can either: - Scroll through the various parameters and screens. - Decrease the value of a set point adjustment.
<b>Buttons      Key combination      Description</b>		
+	1. PRG/MUTE + SET	Holding down for 5 seconds accesses the configuration menu for changing operational parameters. This menu is password protected.
+	2. PRG/MUTE + UP	Hold down for 5 seconds to reset any alarms with manual reset.

## Alarms

### T0 & TS, Alarms

The IR33 controller found in the T0 and TS units comes with a small number of alarm options built in, below is a table showing the alarms used on the basic T0 and TS units, and the resulting action taken by the unit when they occur

Code	Description	Action
E15	High temperature probe 1	Force maximum fan speed
E16	High temperature probe 2	Force maximum fan speed
	Fan failure	Switch off unit
E01	Probe 1 fault	
E02	Probe 2 fault	

### TM Alarms

#### Local Alarms

Code	Description	Action
AL2	High Temperature probe B2	Force maximum fan speed
AL3	High Temperature probe B3	Force maximum fan speed
AL9	Probe B2 fault	Discount probe B2
AL10	Probe B3 fault	Discount probe B3
AL15	All temperature probes fault	Force maximum fan speed
AL19	Fan failure	Switch off unit

#### Network Alarms

Code	Alarm	Description
AL20	Network Error	Problem communicating with TS unit(s)
AL21	High temperature	High temperature alarm on TS unit(s)
AL22	Fan failure	Fan failure alarm on TS unit(s)
AL23	Probe fault	Probe fault alarm on TS unit(s)
AL32	Unit error	Incompatible unit on network

### TX Alarms

#### Local Alarms

Code	Description	Action
AL2	High temperature probe B2	Force maximum fan speed
AL3	High temperature probe B3	Force maximum fan speed
AL4	High temperature probe B4	Force maximum fan speed
AL5	High temperature probe B5	Force maximum fan speed
AL6	High temperature probe B6	Force maximum fan speed
AL7	High temperature probe B7	Force maximum fan speed
AL9	Probe B2 fault	Discount probe B2
AL10	Probe B3 fault	Discount probe B3
AL11	Probe B4 fault	Discount probe B4
AL12	Probe B5 fault	Discount probe B5
AL13	Probe B6 fault	Discount probe B6
AL14	Probe B7 fault	Discount probe B7
AL15	All temperature probes fault	Force maximum fan speed
AL19	Fan failure	Switch off unit
AL33	Master network error	Force stand-alone operation

#### Network Alarms

Code	Description	Action
AL24	High temperature on network unit(s)	
AL25	Probe fault on network unit(s)	
AL26	All temperature probes fault on network unit(s)	Discount network unit(s)
AL28	Fan failure on network unit(s)	Discount network unit(s)
AL31	Problem communicating with network unit(s)	Discount network unit(s)
AL32	Incompatible unit on network	Discount network unit(s)

## Alarms

### V0 Alarms

#### Stand-alone Alarms

Code	Description	Action
AL2	High temperature probe B2	Force maximum fan speed
AL3	High temperature probe B3	Force maximum fan speed
AL4	High temperature probe B4	Force maximum fan speed
AL5	High temperature probe B5	Force maximum fan speed
AL6	High temperature probe B6	Force maximum fan speed
AL7	High temperature probe B7	Force maximum fan speed
AL8	Probe B1 fault	Force temperature control
AL9	Probe B2 fault	Discount probe B2
AL10	Probe B3 fault	Discount probe B3
AL11	Probe B4 fault	Discount probe B4
AL12	Probe B5 fault	Discount probe B5
AL13	Probe B6 fault	Discount probe B6
AL14	Probe B7 fault	Discount probe B7
AL15	All temperature probes fault	Force maximum fan speed
AL16	Low pressure	Force maximum fan speed
AL17	Constant Air Volume high temperature	Switch to temperature control until alarm condition is gone
AL18	Constant Air Volume high temperature maximum trips	Force temperature control until alarm reset
AL19	Fan failure	Switch off unit
AL33	Master network error	Force stand-alone operation

#### Network Alarms

Code	Description	Action
AL24	High temperature on network unit(s)	
AL25	Probe fault on network unit(s)	
AL26	All temperature probes fault on network unit(s)	Discount network unit(s)
AL27	Low pressure alarm on network unit(s)	
AL28	Fan failure on network unit(s)	Discount network unit(s)
AL29	CAV high temperature alarm on network unit(s)	
AL30	CAV high temperature trips alarm on network unit(s)	
AL31	Problem communicating with network unit(s)	Discount network unit(s)
AL32	Incompatible unit on network	Discount network unit(s)

**Troubleshooting**

Fault	Possible cause	Remedy/action
<b>Unit will not start</b>	No power	Check power supply to the controller
	Wired incorrectly	Check wire connections in accordance with wiring diagram on control panel.
	Loose wires	Check all wires, connections, terminals etc
<b>Fan not operating - power on</b>	Power supply failure	Check power supply at circuit breaker
	Wiring to motor	Check voltage at motor terminals
	Motor / fan assembly jammed	Isolate unit and check free rotation of motor/fan assembly, if faulty - replace
	Motor internal overheat protector tripped	The fan should auto reset. If this fails the motor will need to be replaced.
<b>Constant air volume faulty</b>	Pressure sensor not reading correctly	Check position of tubes +ve Red tube connected to the duct connector situated in the control panel.  -ve Blue tube Located on the inlet ring to the fan. Ensure that the tubing forms a continuous loop and is not broken. The static ring connects to both fan inlet rings.
		Ensure all tubes are connected.

## After Sales

### Warranty

All Airedale products or parts (non consumable) supplied for installation within the UK mainland and commissioned by an Airedale engineer, carry a full Parts & Labour warranty for a period of 12 months from the date of commissioning or 18 months from the date of despatch, whichever is the sooner.

Parts or Equipment supplied by Airedale for installation within the UK or for Export that are properly commissioned in accordance with Airedale standards and specification, not commissioned by an Airedale engineer; carry a 12 month warranty on non consumable Parts only from the date of commissioning or 18 months from the date of despatch, whichever is the sooner.

Parts or equipment installed or commissioned not to acceptable Airedale standards or specification invalidate all warranty.

### Warranty is only valid in the event that

In the period between delivery and commissioning the equipment: is properly protected & serviced as per the Airedale installation & maintenance manual provided where applicable the glycol content is maintained to the correct level.

In the event of a problem being reported and once warranty is confirmed as valid under the given installation and operating conditions, the Company will provide the appropriate warranty coverage (as detailed above) attributable to the rectification of any affected Airedale equipment supplied (excluding costs for any specialist access or lifting equipment that must be ordered by the customer).

Any spare part supplied by Airedale under warranty shall be warranted for the unexpired period of the warranty or 3 months from delivery, whichever period is the longer.

To be read in conjunction with the Airedale Conditions of Sale - Warranty and Warranty Procedure, available upon request.

### Procedure

When a component part fails, a replacement part should be obtained through our Spares department. If the part is considered to be under warranty, the following details are required to process this requirement. Full description of part required, including Airedale's part number, if known. The original equipment serial number. An appropriate purchase order number.

A spares order will be raised under our warranty system and the replacement part will be despatched, usually within 24 hours should they be in stock. When replaced, the faulty part must be returned to Airedale with a suitably completed and securely attached "Faulty Component Return" (FCR) tag. FCR tags are available from Airedale and supplied with each Warranty order.

On receipt of the faulty part, suitably tagged, Airedale will pass to its Warranty department, where it will be fully inspected and tested in order to identify the reason for failure, identifying at the same time whether warranty is justified or not.

On completion of the investigation of the returned part, a full "Report on Goods Returned" will be issued. On occasion the release of this complete report may be delayed as component manufacturers become involved in the investigation. When warranty is allowed, a credit against the Warranty invoice will be raised. Should warranty be refused the Warranty invoice becomes payable on normal terms.

### Exclusions

Warranty may be refused for the following reasons.

- Misapplication of product or component
- Incorrect site installation
- Incomplete commissioning documentation
- Inadequate site installation
- Inadequate site maintenance
- Damage caused by mishandling
- Replaced part being returned damaged without explanation
- Unnecessary delays incurred in return of defective component

### Returns analysis

All faulty components returned under warranty are analysed on a monthly basis as a means of verifying component and product reliability as well as supplier performance. It is important that all component failures are reported correctly.







Head Office  
Airedale International Air Conditioning Ltd  
Leeds Road  
Rawdon  
Leeds LS19 6JY

Tel: +44 (0) 113 2391000

Fax: +44 (0) 113 2507219

E-mail: [enquiries@airedale.com](mailto:enquiries@airedale.com)

Web: [www.airedale.com](http://www.airedale.com)



**SYSTEMY HVAC Sp. z o.o.**  
ul. Rydygiera 8, 01-793 Warszawa  
tel.: +48 22 101 74 00  
fax: +48 22 101 74 01  
e-mail: [biuro@systemy-hvac.pl](mailto:biuro@systemy-hvac.pl)  
[www.systemy-hvac.pl](http://www.systemy-hvac.pl)